

NAME: _____ Date: _____ Teacher: _____



Ruler Worksheet



PEER
peer.berkeley.edu

Each group will get a ruler and figure out how long the different pieces of your structure are.

How long is the red rod? _____ Inches



How long is the grey rod? _____ Inches



How wide is this joint piece? _____ Inches

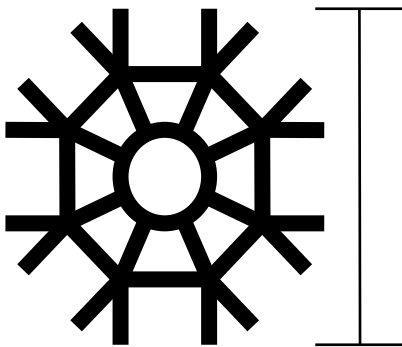

How wide, long, and tall is your structure?

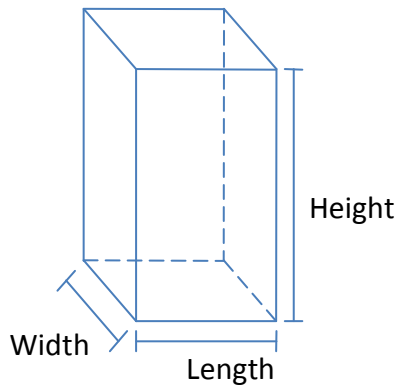

Length = _____ Inches

Width = _____ Inches

Height = _____ Inches